

SE

SUBMINIATURE TEMPERATURE SWITCHES



General information:

SE series subminiature temperature switches are low cost options. They are generally used where size is a constraint. Typical applications are to sense temperature. Can also be used for several automation applications.

Features:

- Compact
- Lightweight (Approx. 0.11 Kg.)
- Normally closed (NC) or normally open (NO) or SPDT
- Electrical rating: 5A, 250VAC; 0.2A, 250 VDC (res.)
- Switching point easy to adjust
- Material : Body - Aluminium; Pressure housing - Brass/SS
- Pressure port : 1/4" BSP(M), other sizes available

Range Selection Table

Range Code	Range °C (°F)	Differential °C (°F)	Maximum Working Temperature °C (°F)
T1H	25 - 90 (77 - 194)	15 (59)	150 (302)

How to order SE Series Subminiature Temperature Switches

Group 1	Group 2	Group 3	Group 4	Group 5	Group 6	Group 7	Group 8
Non Standard Allocation	Model	Terminal Type	Switch Type	Range Code	Operating Type	Temperature Bulb Material / Size	Length
<input type="checkbox"/> Reserved for non-standard options not mentioned in catalogue. Will be given by manufacturer, only after agreement of supply details with customer.	SE = Subminiature Type	1 = Plug Type	TFO = Temperature Switch Fixed Differential	T1H = (25 - 90)	A1 = With Silver Contact NC A2 = With Silver Contact NO A3 = With Silver Contact SPDT	S3 = SS316L / 1/4" BSPM B3 = Brass / 1/4" BSPM	0 = Dia. 6 mm, 20 mm length

e.g.: A temperature subminiature switch, temperature range from 25 - 90 °C in uncalibrated style with brass pressure port & dia. 6mm, 20mm length shall be specified by

Group 1	Group 2	Group 3	Group 4	Group 5	Group 6	Group 7	Group 8
<input type="checkbox"/>	SE	1	TFO	T1H	A1	B3	0

Please specify full model number to avoid ambiguity. If only the first two groups are specified while ordering, switches with standard wetted parts will be supplied.

Installation and Operating instructions

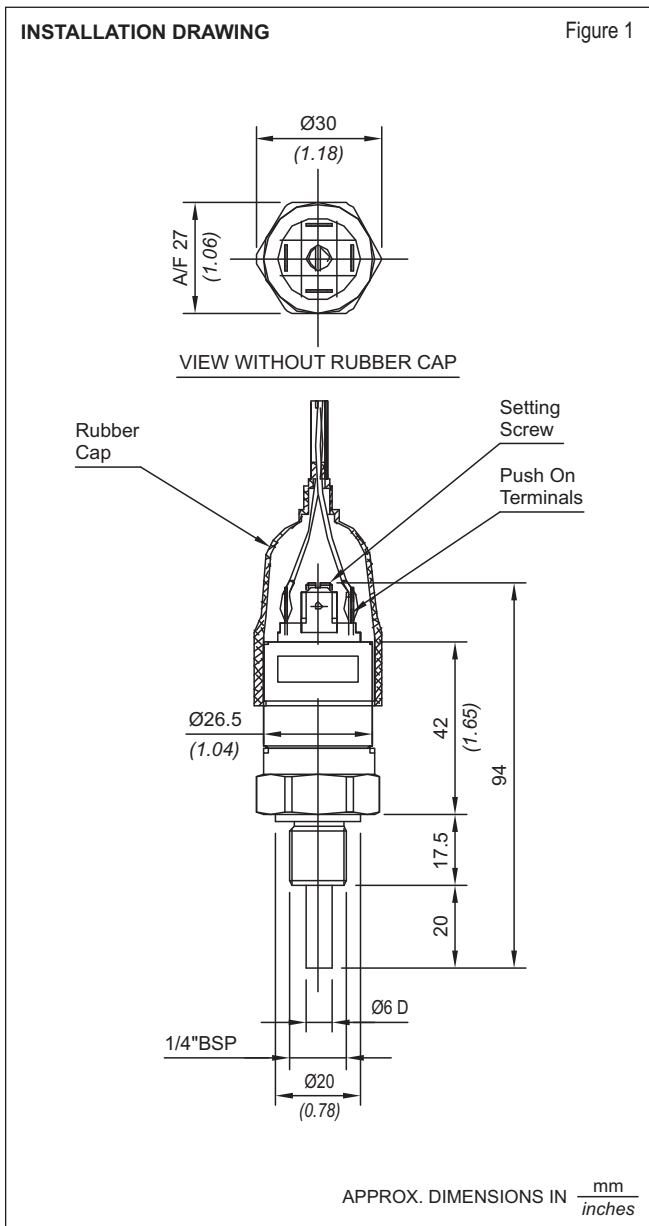

Construction :

The temperature switch is housed in a rolled aluminium enclosure. The temperature capsule, at the bottom of the switch, comprises a temperature housing (Brass/SS), a disc and a temperature bulb. This is a plug type switch with NO (Normally Open) or NC (Normally Closed) or SPDT contacts. The electrical terminations are standard Push On type.

Principle of Operation:

Temperature being sensed by the bulb is in direct proportion to the pressure of the liquid filled in the temperature sensing capsule. As the temperature being sensed changes, so does the vapour pressure inside the bulb. This change in pressure is sensed by a diaphragm and a compression spring. Once the pressure changes beyond the set limit, an electrical element is actuated.

Materials of Construction :

Housing : Rolled Aluminium
Temperature bulb : Brass/ SS

Mounting :

- 1) The SE series subminiature switches have stem type mounting and can be mounted in any direction.
- 2) The pressure port size is generally 1/4" BSP(M), unless specifically ordered otherwise. Other sizes can be obtained via adaptors for small quantities. For larger quantities, customized thread ends can be provided.

CAUTION : Tightening torque should not exceed by 4kg-m.

Electrical Connections :

These pressure switches will generally have NO (Normally Open) or NC (Normally Closed) or SPDT contact terminals. Figure. 2.

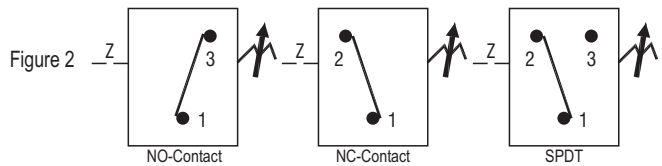

Wiring :

Connect the wires to the contact terminals as per your wiring diagram.

Set Point Adjustment :

- 1) The switching point can be easily adjusted by turning the setting screw located in between the contacts. Figure. 1.
- 2) Apply the desired cutin (lower) / cutout (higher) temperature to the sensing bulb of the switch.
- 3) Increase the temperature setting by turning the setting screw till contacts changeover.
- 4) Some minor adjustment will be required to achieve the exact cutin (lower) / cutout (higher) point, which can be checked with the help of a proper temperature measurement device.

Tip : The temperature switches are factory set at half the set point range (unless otherwise specified in a Purchase Order).

Trouble Shooting Tips

WARNING: Isolate the switch electrically and disconnect from pressure source before carrying out trouble shooting, in a safe area. Generally no problems are observed if the temperature switch selection, wiring and the set point is proper. For a temperature switch selection procedure, please consult our sales office.

For properly selected temperature switches, if following symptoms are observed, the likely causes and remedies are as stated below.

Symptom 1: Switch Does Not Operate

- 1) Wiring may not be correct, Check electrical connections to the temperature switch, if they are as per the wiring diagram.
- 2) The temperature bulb does not sense temperature.

DO NOT TAMPER THE TEMPERATURE BULB IN ANY EVENT.

If the cause is none of the above-mentioned probabilities, proceed as per the following steps.

Check the system temperature & set point of temperature switch.

For use of temperature switch for falling set points, system temperature has to be greater than the cut out point.

For use of temperature switch for rising set points, the system temperature may not be reaching the cutout point.

If the switch still does not operate, remove the temperature switch physically from the system. There should be continuity between terminals. If no continuity is observed the temperature switch should be returned to the factory.

Symptom 2: Leakage

In case leakage is observed, the temperature switch has to be returned to the factory without tampering the temperature bulb.