

FC/FE

LOW PRESSURE RANGES



FC



PRESSURE CAPSULE DETAILS

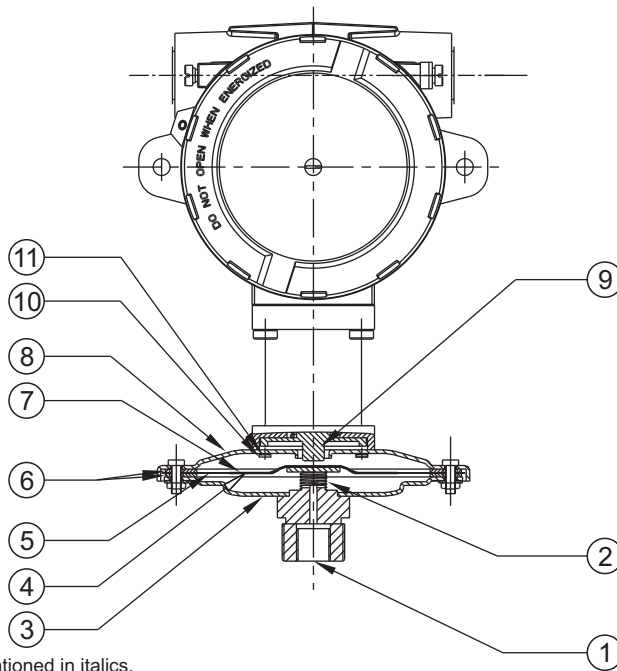

No. Description

1. Pressure port (S.S.)*
2. Support spring (S.S.)
3. Bottom flange (S.S.)
4. Support plate (Aluminium)
5. Diaphragm (Neoprene)
6. Gasket (Nitrile)
7. Top plate (Aluminium)
8. Top flange (S.S.)
9. Plunger (Aluminium)
10. Top flange screw (S.S.)
11. Sealing 'O' ring (Nitrile)

Note : *wetted parts* are mentioned in italics.

*Pressure port is brazed with flange

INSTALLATION DRAWING

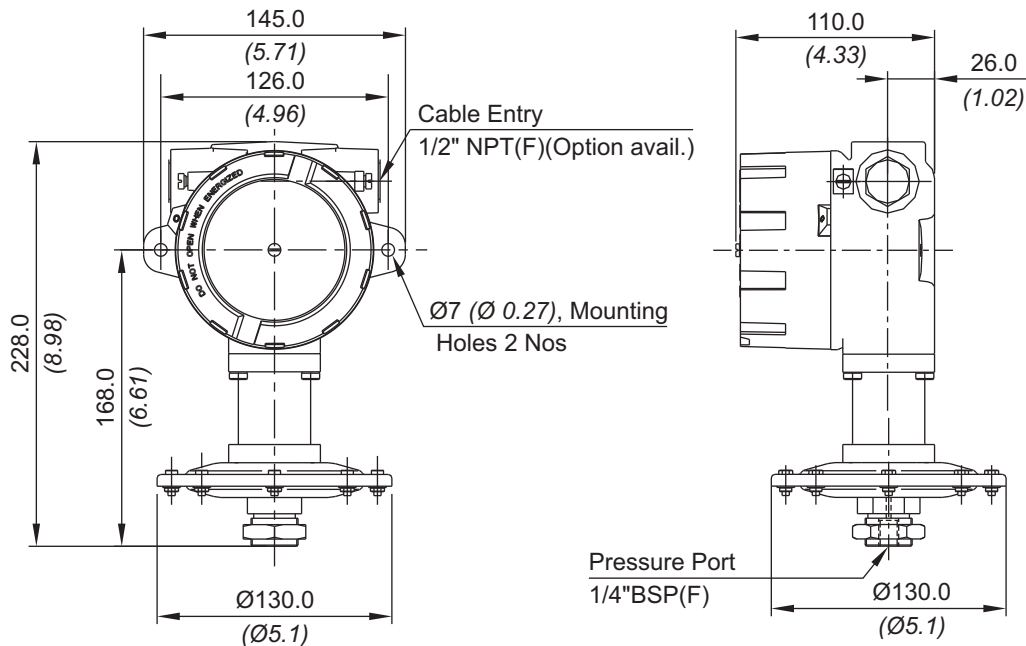

APPROX. DIMENSIONS IN $\frac{\text{mm}}{\text{inches}}$



FE



PRESSURE CAPSULE DETAILS

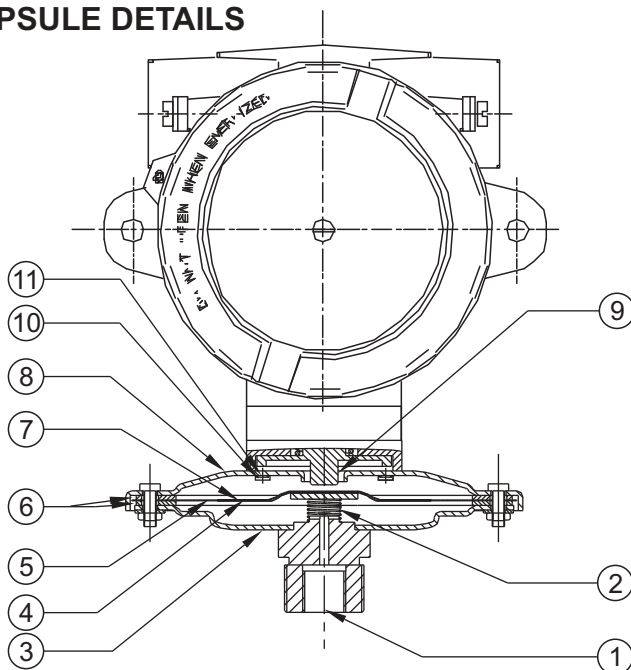

No. Description

1. Pressure port (S.S.)*
2. Support spring (S.S.)
3. Bottom flange (S.S.)
4. Support plate (Aluminium)
5. Diaphragm (Neoprene)
6. Gasket (Nitrile)
7. Top plate (Aluminium)
8. Top flange (S.S.)
9. Plunger (Aluminium)
10. Top flange screw (S.S.)
11. Sealing 'O' ring (Nitrile)

*Pressure port is brazed with flange

Note : *wetted parts* are mentioned in italics.

INSTALLATION DRAWING

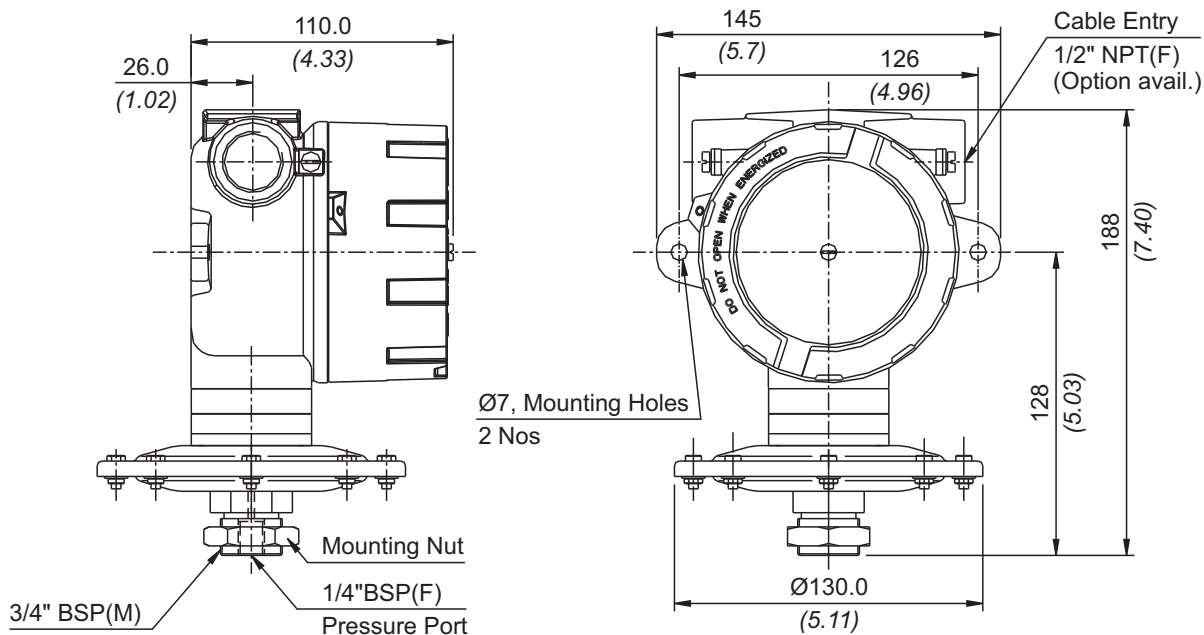

APPROX. DIMENSIONS IN $\frac{\text{mm}}{\text{inches}}$

FC/FE LOW PRESSURE RANGES

RANGE SELECTION TABLE

Range Code	Range mbar ("wc)	Differential* mbar ("wc)	Maximum Working Pressure bar (psi)
		Approximate Maximum for "A1" microswitch	
L02	1.5 - 15 (0.602 - 6.021)	3 (1.204)	2 (29.00)
L03	5 - 25 (2.007 - 10.037)	5 (2.007)	2 (29.00)
L05	10 - 50 (4.015 - 20.073)	5 (2.007)	2 (29.00)
L10	10 - 100 (4.015 - 40.150)	5 (2.007)	2 (29.00)
L15	10 - 150 (4.015 - 60.22)	5 (2.007)	2 (29.00)
L25	20 - 250 (8.029 - 100.36)	10 (4.015)	2 (29.00)
L35	50 - 350 (20.073 - 140.52)	25 (10.04)	2 (29.00)

*Minimum differential increases with setpoint, values with neoprene diaphragm (Graphs available on request)

* Differentials of microswitches A2 through A9 will vary. Differentials for A7 are typically twice that for A1 microswitch. Please indicate specifically the differential value in enquiry/order, when it is critical in your application.

HOW TO ORDER FLAMEPROOF LOW RANGE PRESSURE SWITCHES

Group 1	Group 2	Group 3	Group 4	Group 5	Group 6	Group 7	Group 8
Non standard allocation	Gas Group Classification	Cable Entry Size	Switch Type	Range Code (values in mbar)	Microswitch Type	Pressure Port Material / Size	Diaphragm
<input type="checkbox"/> Reserved for non-standard options not covered in catalogue. Will be given by manufacturer, only after agreement of supply details with customer.	FC = Flameproof pressure switch, ATEX & IECEx approved, with Aluminium head as per IS/IEC 60079-1 for Gas Gr. IIC FE = IP66 Flameproof pressure switch, KLPL approved	1 = Al. head 1/2" NPT threads 2 = Al. head 3/4" NPT threads 3 = Al. head M20 x 1.5 threads 4 = Grey CI head 1/2" NPT threads 5 = Grey CI head 3/4" NPT threads 6 = Grey CI head M20 x 1.5 threads 7 = SS head 1/2" NPT threads 8 = SS head 3/4" NPT threads 9 = SS head M20 x 1.5 threads	P1 = pressure switch, fixed differential without scale P2 = pressure switch, fixed differential with scale in mbar P3 = pressure switch, fixed differential with scale in "wc	L02 = (1.5 - 15) L03 = (5 - 25) L05 = (10 - 50) L10 = (10 - 100) L15 = (10 - 150) L25 = (20 - 250) L35 = (50 - 350)	A1 = General purpose microswitch rated at 15 A; 250 VAC A2 = Hermetically sealed for corrosive environments A3 = gold plated contacts for low voltage applications A4 = DPDT configuration A5 = for high DC ratings A6 = elements with adjustable deadband A7 = 2SPDT switching elements A9 = General purpose microswitch rated at 5 A; 250 VAC Please refer Page No. 69 for Microswitch options * Please refer note under Range Selection Table	S1 = SS316 / 1/4" BSP(F) S2 = SS316 / 1/4" NPT(F)	0 = Neoprene 1 = Teflon 2 = SS316L

eg. A flameproof switch for gas group IIC, with 1/2" NPT cable entry in aluminium housing as 1SPDT pressure switch, having 5 mbar to 25 mbar pressure range, with 15Amp. microswitch, SS316 pressure housing with 1/4" BSP port size & neoprene diaphragm shall be specified by

Group 1	Group 2	Group 3	Group 4	Group 5	Group 6	Group 7	Group 8
<input type="checkbox"/>	FC	1	P1	L03	A1	S1	0

Please specify full model number to avoid ambiguity. If only the first two groups are specified while ordering, uncalibrated switches with standard wetted parts and enclosures will be supplied.

LOW PRESSURE RANGES

FC/FE